



Installation Instructions

10 Ch Peak & Hold Injector Driver

PN 30-2710

WARNING:

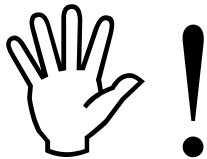

This installation is not for the electrically challenged! Use this ignition with **EXTREME** caution! If you are uncomfortable with anything about this, please refer the installation to an AEM trained tuning shop or call 800-423-0046 for technical assistance. You should also visit the AEM Performance Electronics Forum at <http://forum.aempower.com>

NOTE: AEM holds no responsibility for any engine damage that results from the misuse of this product!

This product is legal in California for racing vehicles only and should never be used on public highways.

IMPORTANT!

Read these instructions completely before attempting this installation!

The AEM 10 Channel Peak & Hold Injector drivers contains 10 independent injector drive channels. It's typical function is to supply full battery voltage to fuel injectors for rapid current rise, in order to produce positive injector opening. When load current reaches 4.1A, the injector driver reduces the load current to 1.1A and operates as a constant current source. This condition holds the injector open and reduces system power dissipation. If the current fails to reach 4.1A within 5mS, the driver module automatically reduces the load current to 1.1A.

NOTE: It is strongly recommended that you have a wiring diagram for your specific vehicle before attempting to install the AEM P&H driver module.

TECHNICAL FEATURES

Operating Voltage:	8-18 volts, negative ground
RPM Capability:	Unlimited
Injector Triggers:	10
Trigger Waveform:	Output is activated when trigger is grounded
Trigger Impedance:	220 Ohm input impedance, pulled to 12V (60 mA draw)
Injector Outputs:	10
Output Current High:	4.15A Peak, Typical
Output Current Low:	1.15A Sustain, Typical
Peak Current Timeout:	5mS
Size:	5.5"L x 4.6"W x 1.4"H
Weight:	2.7 Lbs
Over temperature Shutdown:	115C (Nominal)

BATTERY

The AEM P&H Driver is designed for negative ground, 12 volt and 16 volt electrical systems.

WELDING

Before welding on your vehicle, disconnect the AEM P&H Driver power cables from the battery. Failure to do so may damage your ignition.

MOUNTING

The AEM P&H Driver may be mounted in any position as long as it is not in an enclosed location nor near a large heat source. It may not be mounted directly to the engine nor should it be mounted near or above the exhaust manifold(s).

WIRING**GENERAL WIRING RECOMMENDATIONS**

- Solder wire joints for the most trouble-free connections.
- Always run wires away from direct heat and sharp edges.
- A poor ground connection is the leading cause of ignition problems.
- Connect ground wires directly to the negative (-) battery terminal or engine block.
- There must be a ground strap connecting the engine to the chassis.
- If connecting a ground to the engine block, ensure it is a clean, paint free metal surface.

AEM P&H INJECTOR DRIVER WIRE FUNCTIONS

There are 2 connectors on the end of the case:

GREY Connector (INPUT)

#	Name	Color	Function
1.	Injector 1 In	Pink	Injector 1 Trigger input
2.	Injector 2 In	Brown	Injector 2 Trigger input
3.	Injector 3 In	Orange	Injector 3 Trigger input
4.	Injector 4 In	Dark Green	Injector 4 Trigger input
5.	Injector 5 In	Grey	Injector 5 Trigger input
6.	Injector 6 In	Dark Blue	Injector 6 Trigger input
7.	Injector 7 In	Violet	Injector 7 Trigger input
8.	Injector 8 In	Tan	Injector 8 Trigger input
9.	Injector 9 In	Yellow	Injector 9 Trigger input
10.	Injector 10 In	Light Green	Injector 10 Trigger input
11.	Power Ground	Black	Ground Input - Connect to the Battery (-) or a good chassis ground
12.	Power Ground	Black	Ground Input - Connect to the Battery (-) or a good chassis ground

BLACK Connector (OUTPUT)

#	Name	Color	Function
1.	Injector 1 Out	Pink	Injector 1 Output (ground side) connect 12V to other side of injector.
2.	Injector 2 Out	Brown	Injector 2 Output (ground side) connect 12V to other side of injector.
3.	Injector 3 Out	Orange	Injector 3 Output (ground side) connect 12V to other side of injector.
4.	Injector 4 Out	Dark Green	Injector 4 Output (ground side) connect 12V to other side of injector.
5.	Injector 5 Out	Grey	Injector 5 Output (ground side) connect 12V to other side of injector.
6.	Injector 6 Out	Dark Blue	Injector 6 Output (ground side) connect 12V to other side of injector.
7.	Injector 7 Out	Violet	Injector 7 Output (ground side) connect 12V to other side of injector.
8.	Injector 8 Out	Tan	Injector 8 Output (ground side) connect 12V to other side of injector.
9.	Injector 9 Out	Yellow	Injector 9 Output (ground side) connect 12V to other side of injector.
10.	Injector 10 Out	Light Green	Injector 10 Output (ground side) connect 12V to other side of injector.
11.	POS 12V	Red	Power Input - Connect to a switched +12v source.
12.	POS 12V	Red	Power Input - Connect to a switched +12v source.

INJECTOR DRIVER REQUIRES
A LOW, OR GROUNDED INPUT
TO FIRE THE INJECTORS

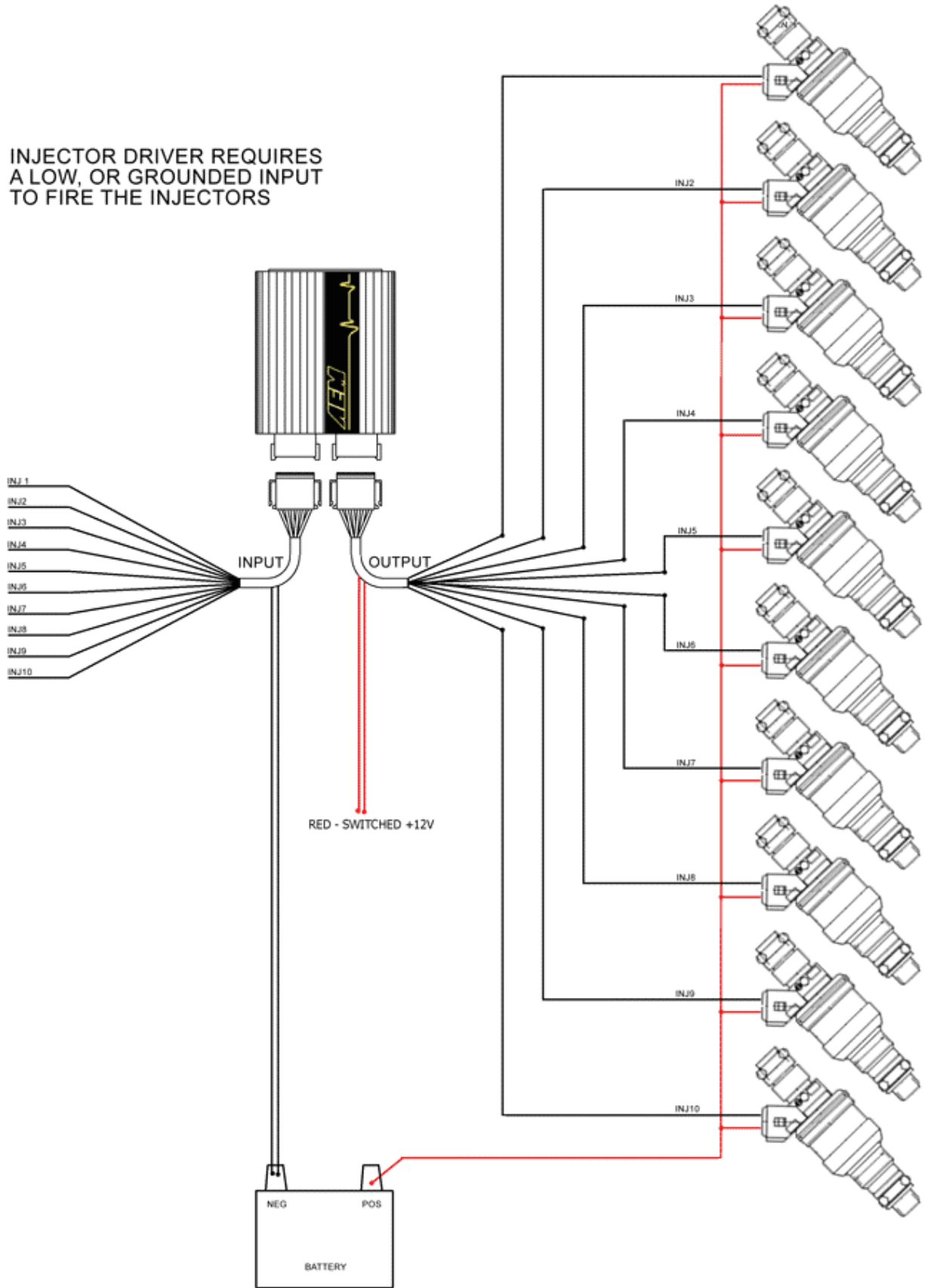

12 MONTH LIMITED WARRANTY

Advanced Engine Management Inc. warrants to the consumer that all AEM High Performance products will be free from defects in material and workmanship for a period of twelve (12) months from date of the original purchase. Products that fail within this 12 month warranty period will be repaired or replaced at AEM's option, when determined by AEM that the product failed due to defects in material or workmanship. This warranty is limited to the repair or replacement of the AEM part. In no event shall this warranty exceed the original purchase price of the AEM part nor shall AEM be responsible for special, incidental or consequential damages or cost incurred due to the failure of this product. Warranty claims to AEM must be transportation prepaid and accompanied with dated proof of purchase. This warranty applies only to the original purchaser of product and is non-transferable. All implied warranties shall be limited in duration to the said 12 month warranty period. Improper use or installation, accident, abuse, unauthorized repairs or alterations voids this warranty. AEM disclaims any liability for consequential damages due to breach of any written or implied warranty on all products manufactured by AEM. Warranty returns will only be accepted by AEM when accompanied by a valid Return Goods Authorization (RGA) number. Credit for defective products will be issued pending inspection. Product must be received by AEM within 30 days of the date that the RGA is issued.

Please note that before we can issue an RGA for an AEM Electronic Component, it is first necessary for the installer or end user to contact our Performance Electronics Help Desk at 1-310-484-2322 x303 to discuss the problem. Most issues can be solved over the phone. Under no circumstances should a system be returned or an RGA requested before the above process transpires.